

PARTI DI RICAMBIO

SPARE PARTS

PIÈCES DE RECHANGE

ERSATZTEILEN

REPUESTOS

ЗАПАСНЫЕ ЧАСТИ

SMONTAGOMME

TYRE CHANGING MACHINE

DÉMONTE PNEUS

REIFENWECHSLER

DESMONTA-NEUMATICOS

ШИНОМОНТАЖНЫЙ СТАНОК

N° 103177 REV. 3

N° 103178 REV. 2

N° 102733 REV. 6

N° 103179 REV. 2

N° 103180 REV. 7

N° 101045 REV. 13

N° 101039 REV. 0

N° 100078 REV. 0

N° 100183 REV. 0

GUFO ML450

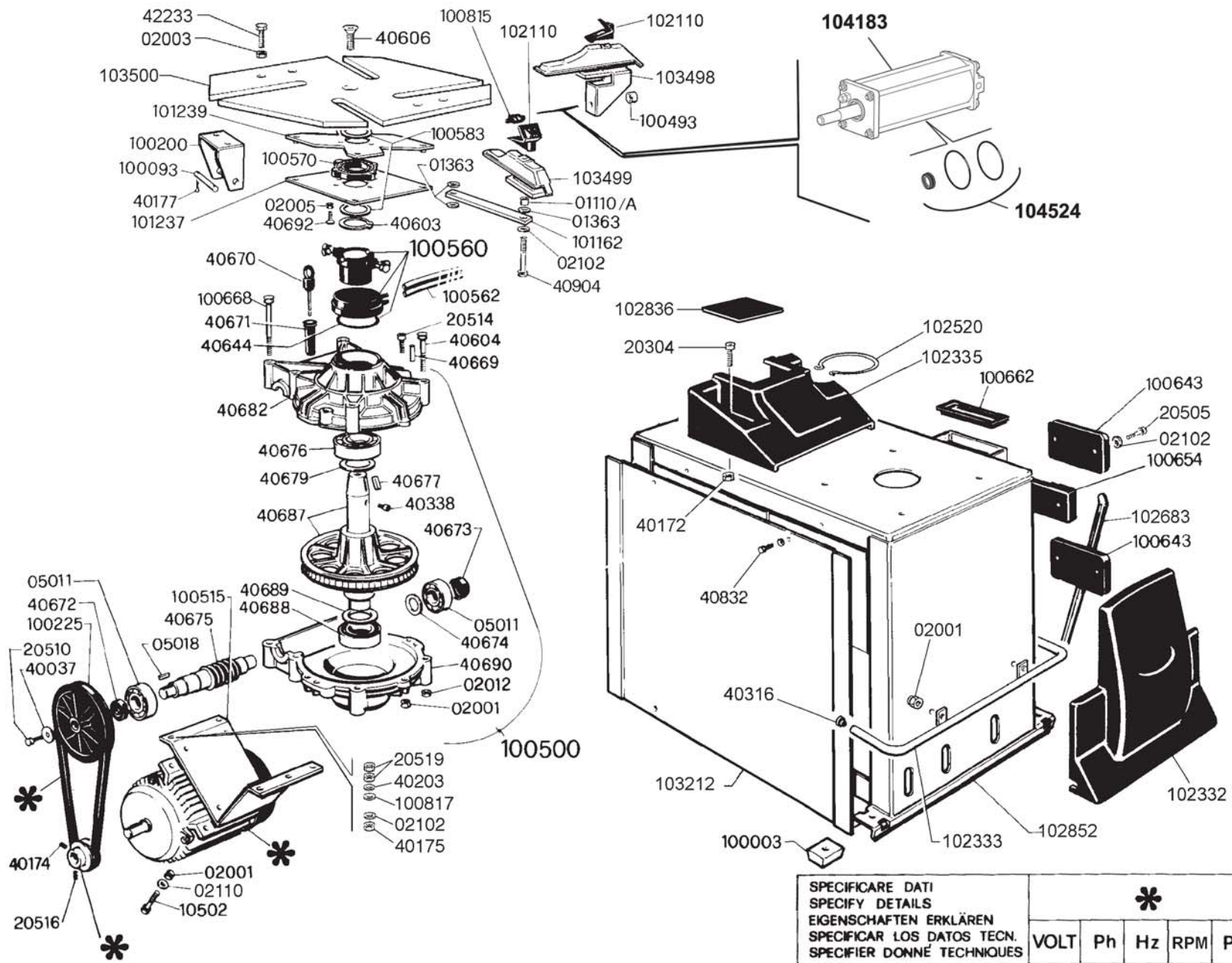

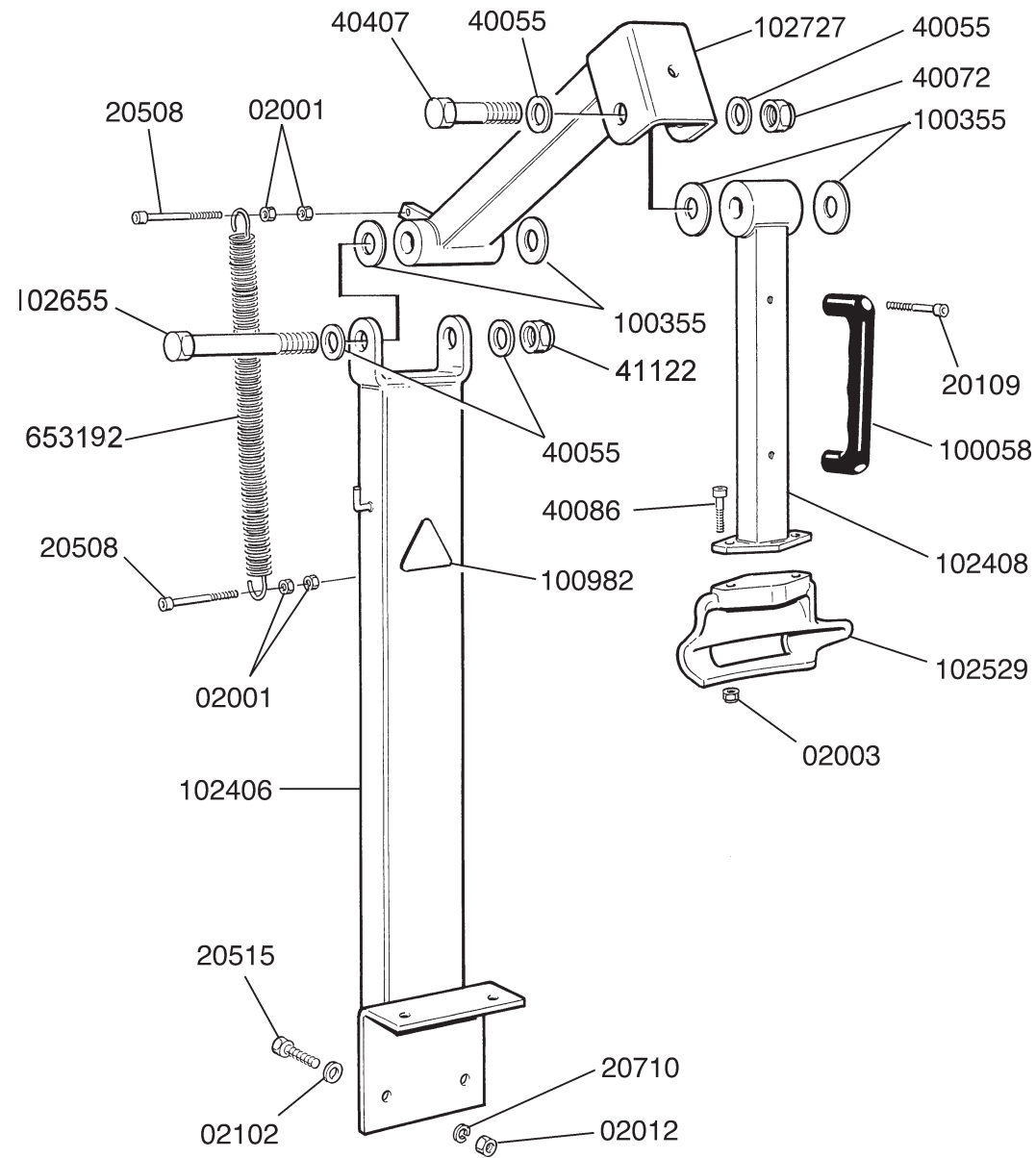

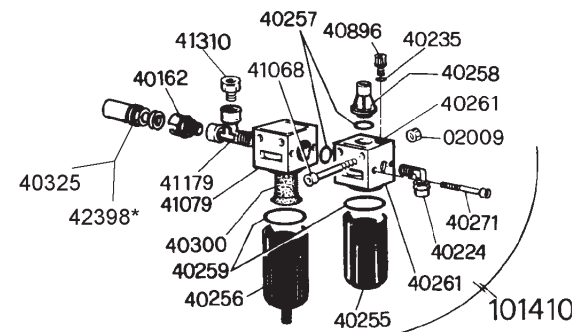
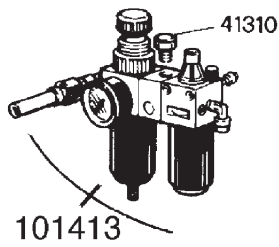
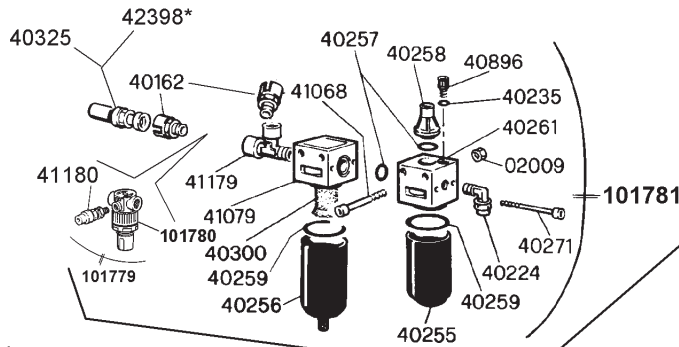
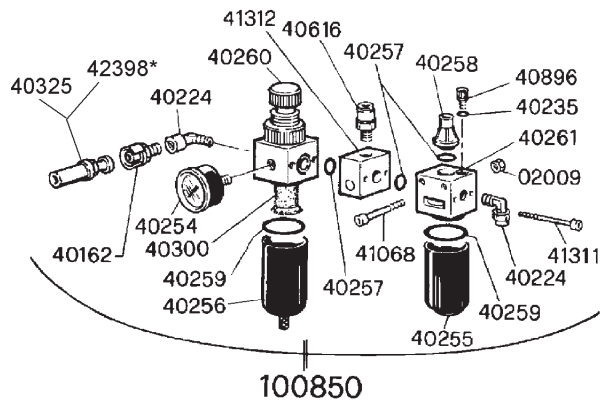
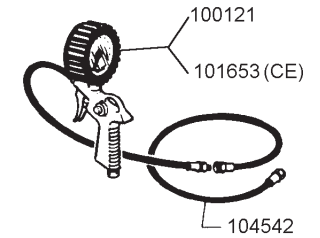
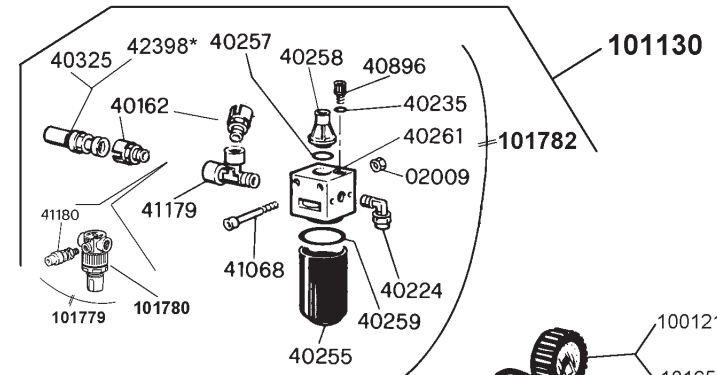
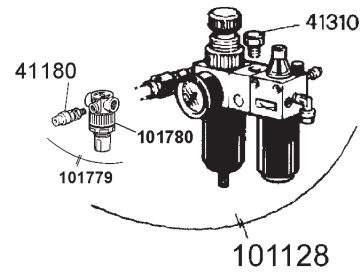
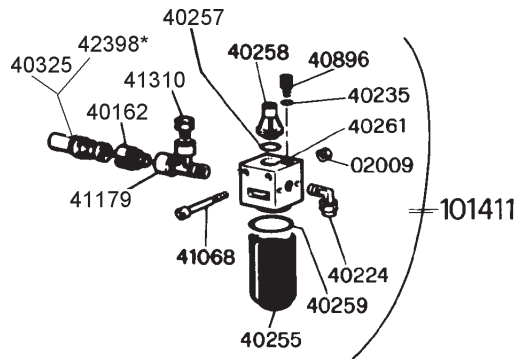

101129

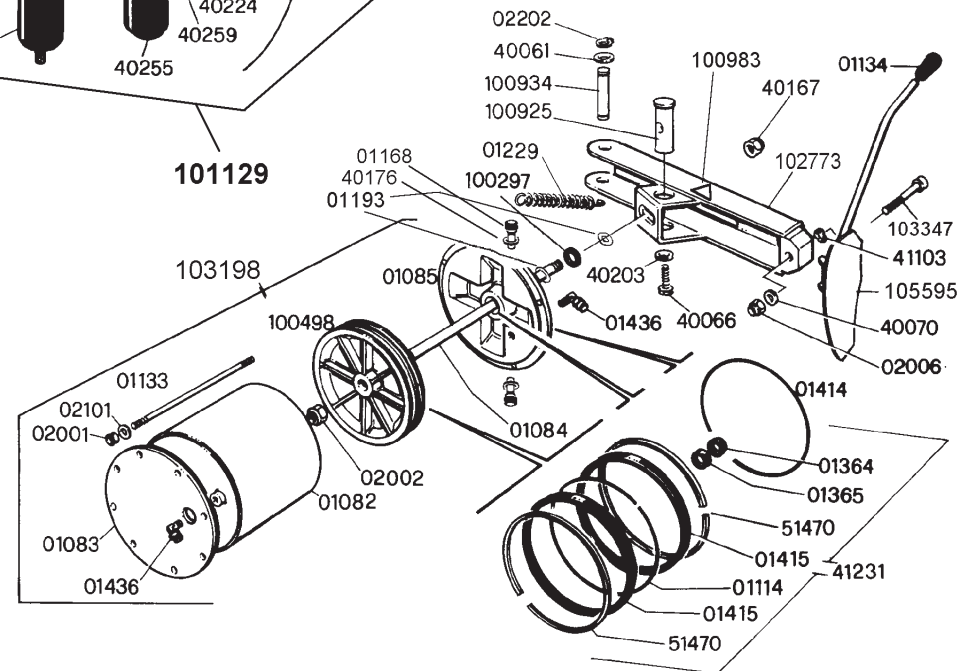

* only for Germany

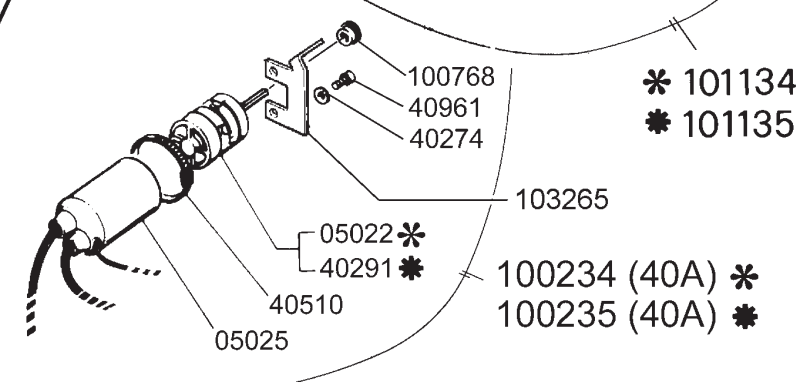
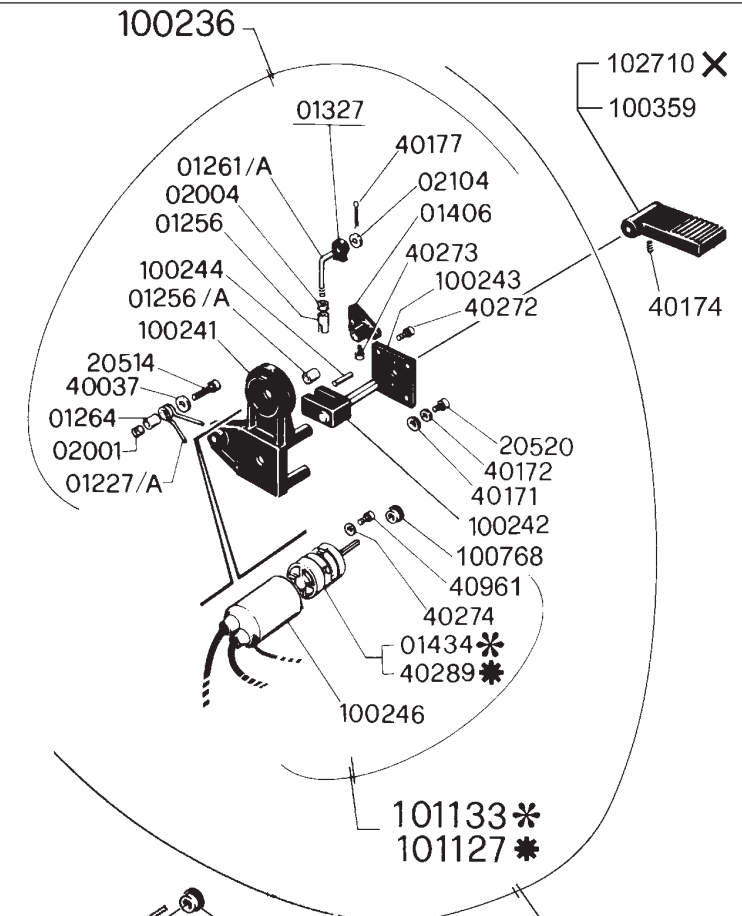
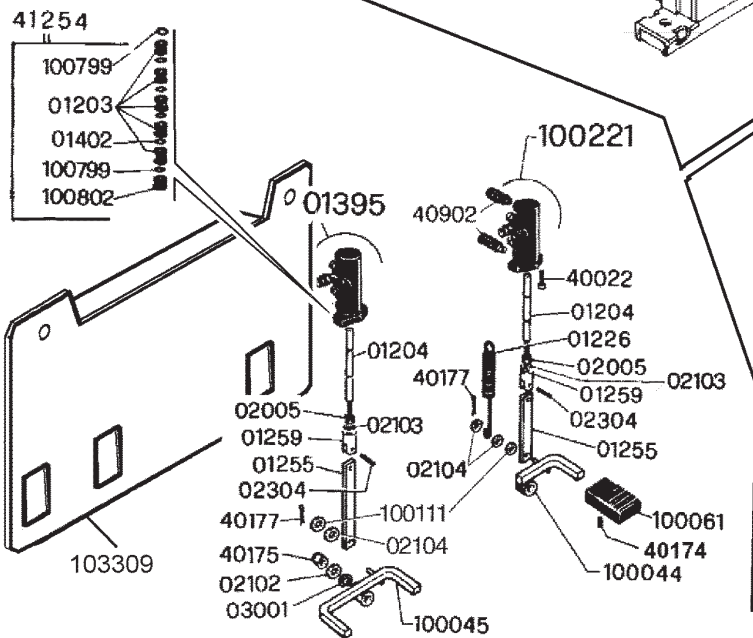
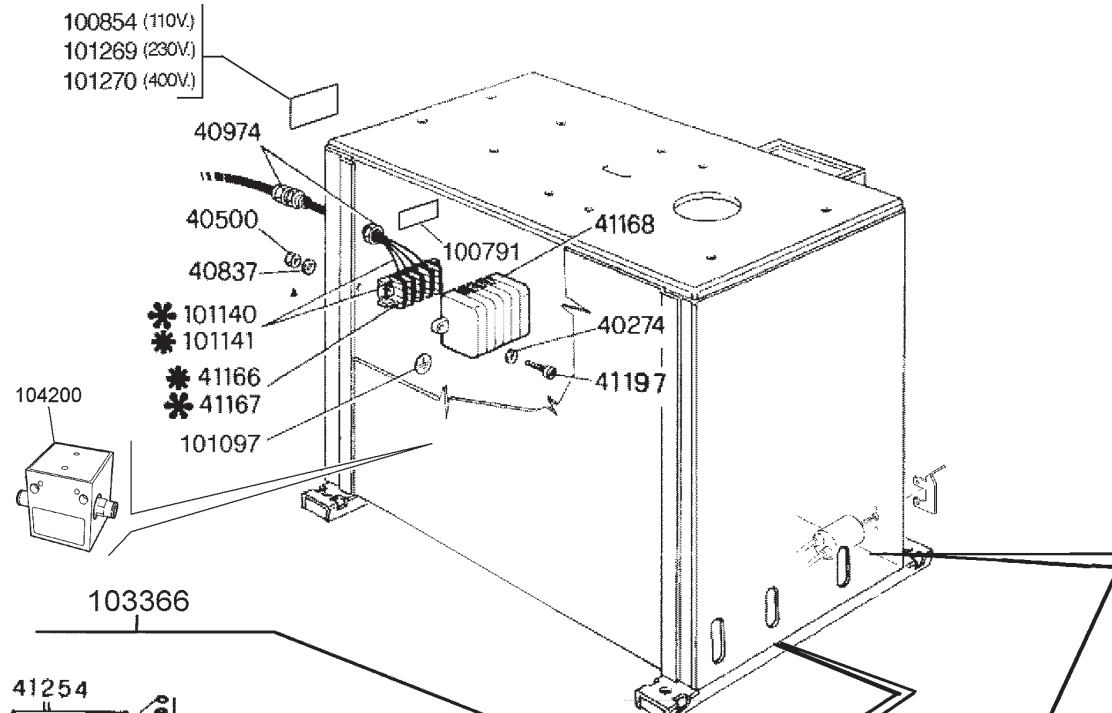

- * 1 Ph
- * 3 Ph
- X 110V 1Ph 40A

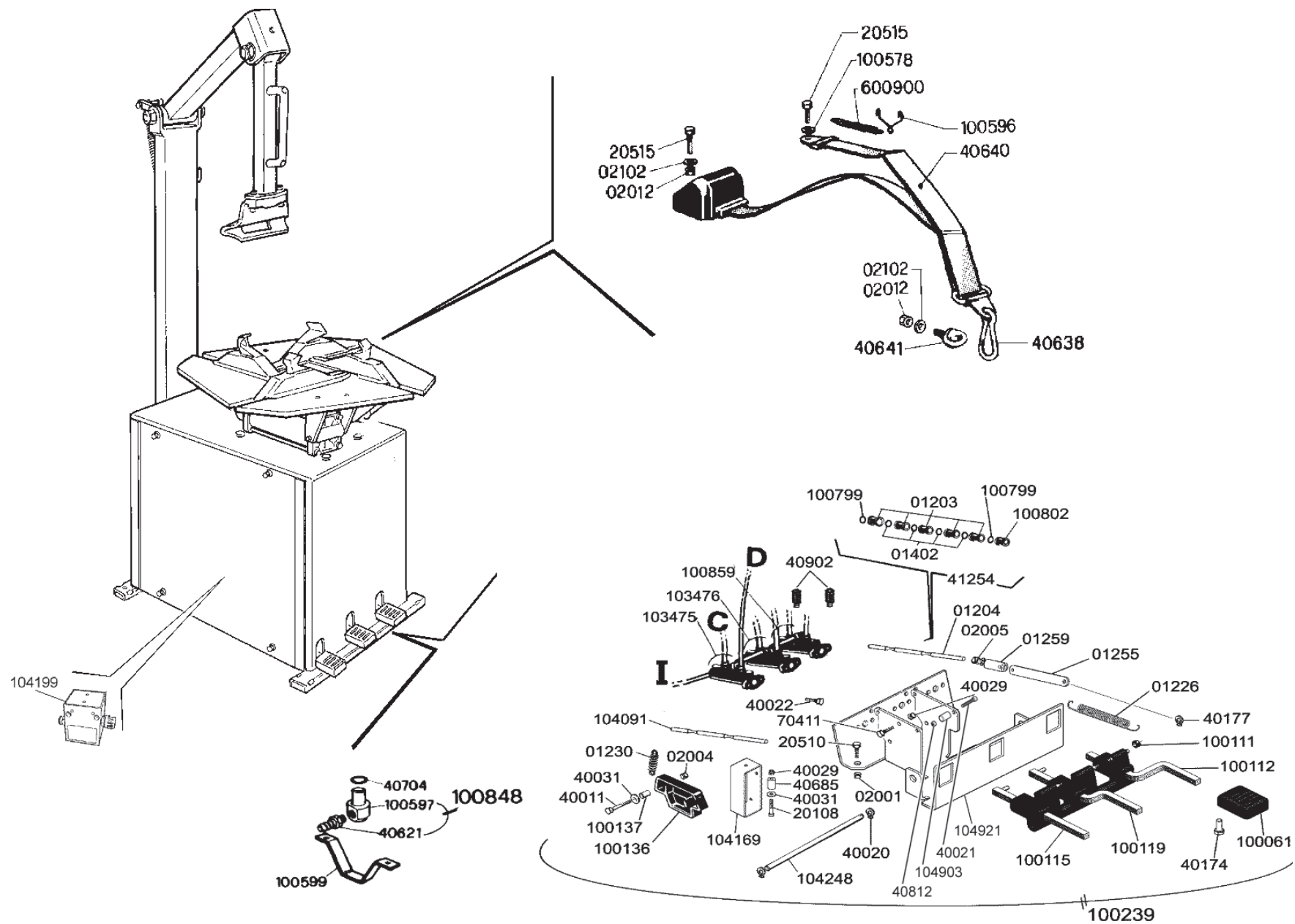

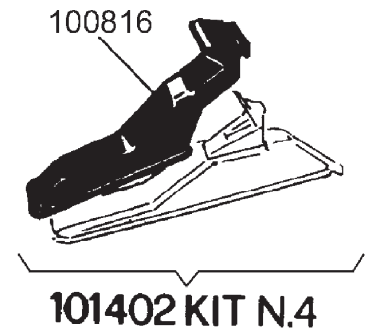
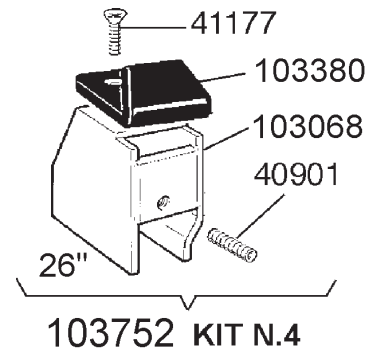
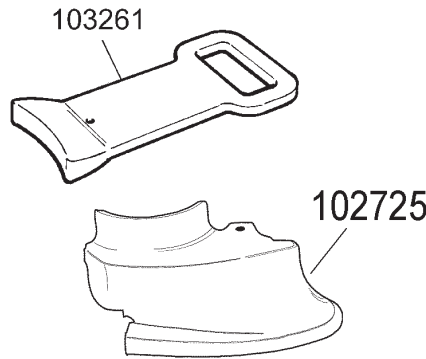
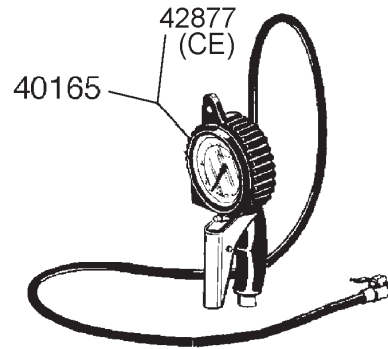
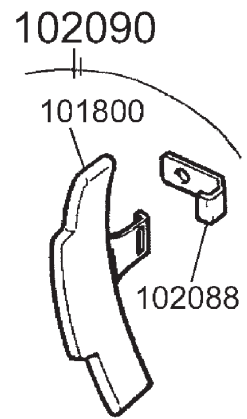

MOTORCYCLE

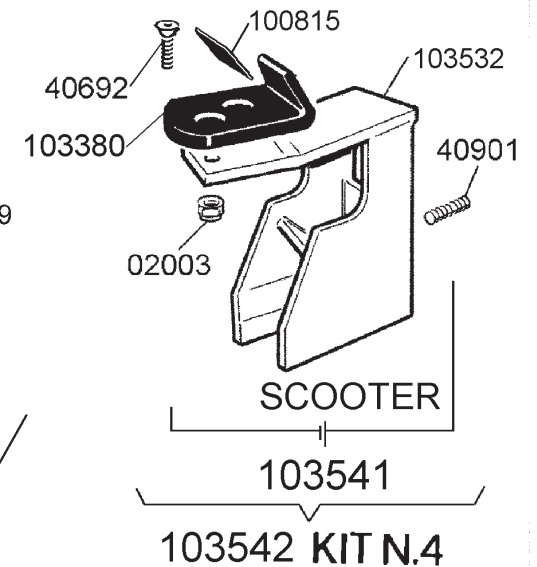
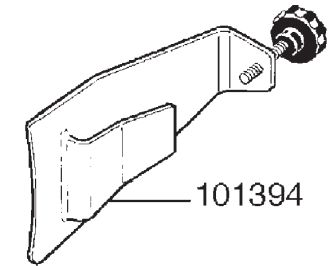
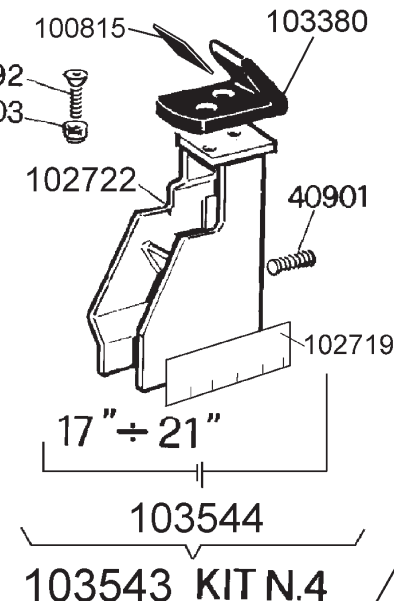
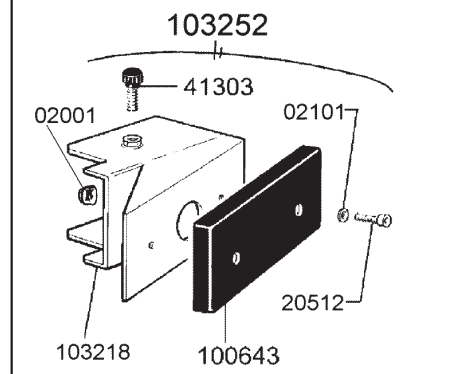
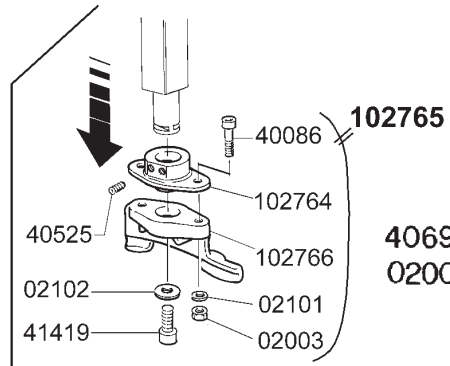
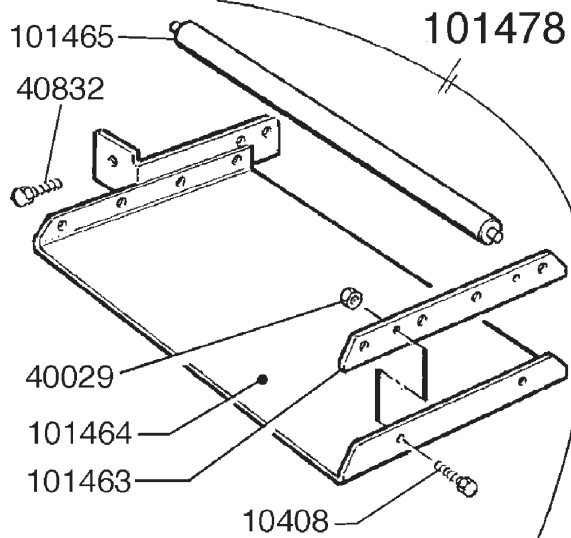
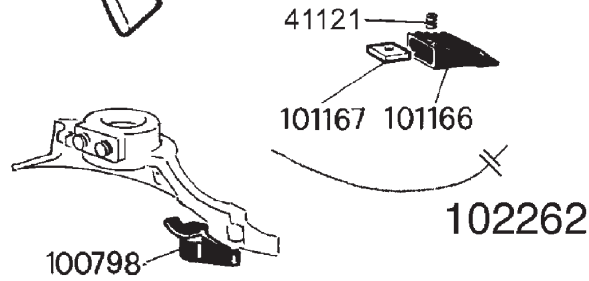

SCHEMA IMPIANTO PNEUMATICO

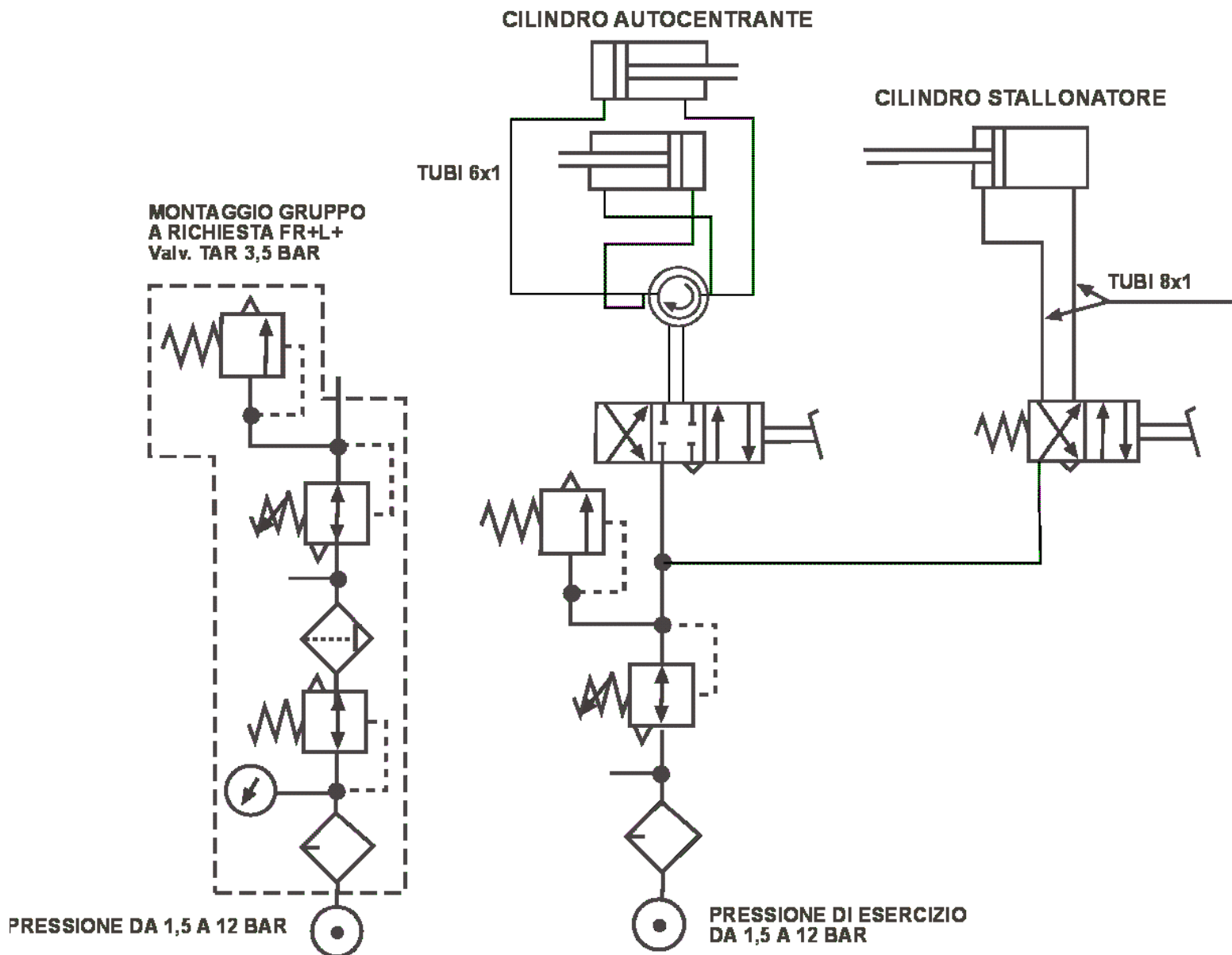

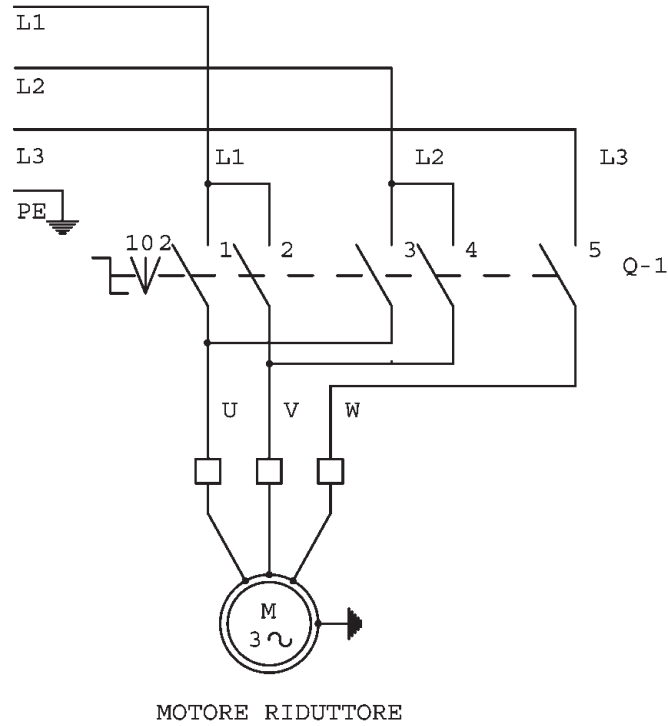

Q-1

	X	X		X		2	POS.
						0	
X			X	X		1	
1	2	3	4	5	6	CONT.	
I	II	III	ELEM.				

- 1-ROTAZIONE ORARIA
- 2-ROTAZIONE ANTIORARIA

DISEGNO : 100078	DATA	DIS
	21/11/02	PEL
3 Ph - 1 speed		

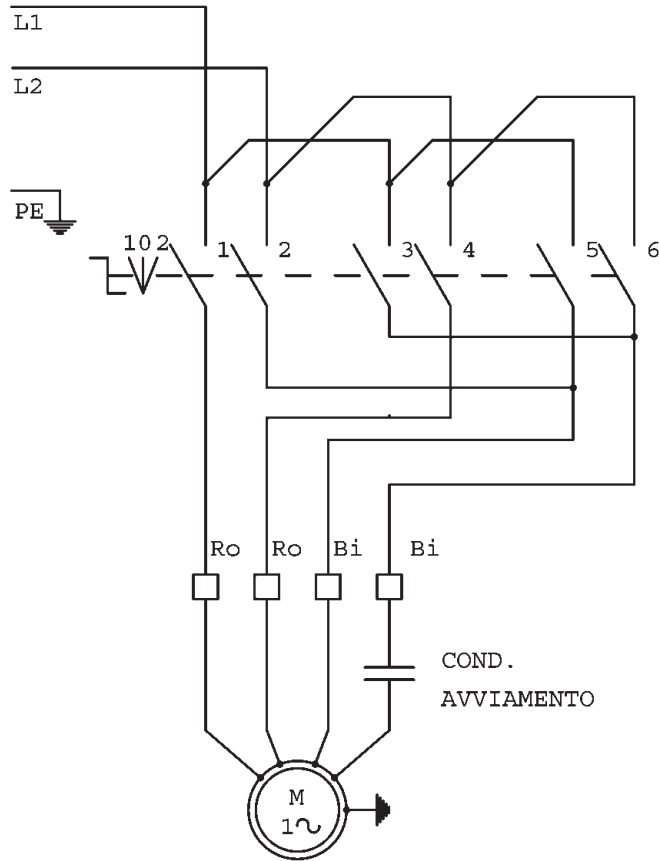

Q-1

Q-1

X			X	X	X	2	POS.
						0	
X	X	X	X				1
1	2	3	4	5	6	CONT.	
I	II		III		ELEM.		

- 1-ROTAZIONE ORARIA
- 2-ROTAZIONE ANTIORARIA

MOTORE RIDUTTORE

DISEGNO : 100183	DATA	DIS
	21/11/02	PEL
1 Ph - 1 speed		



SICAM S.r.l.

Via della Costituzione 49

42015 Correggio (RE) ITALY

Tel. +39 0522 643311

Telefax: + 39 0522 637760

<http://www.sicam.it>

sales@sicam.it